



Visualisation; Diagnostics

Easy to Configure

Programming IEC 61131-3

Rapid Installation

## PSEN cs6.1n

► PSEN sensor technology

**PILZ**  
THE SPIRIT OF SAFETY

This document is the original document.

All rights to this documentation are reserved by Pilz GmbH & Co. KG. Copies may be made for the user's internal purposes. Suggestions and comments for improving this documentation will be gratefully received.

Source code from third-party manufacturers or open source software has been used for some components. The relevant licence information is available on the Internet on the Pilz homepage.

Pilz®, PIT®, PMI®, PNOZ®, Primo®, PSEN®, PSS®, PVIS®, SafetyBUS p®, SafetyEYE®, SafetyNET p®, the spirit of safety® are registered and protected trademarks of Pilz GmbH & Co. KG in some countries.



SD means Secure Digital

<b>Introduction</b> .....	<b>5</b>
Validity of documentation .....	5
Using the documentation .....	5
Definition of symbols .....	5
<b>Safety</b> .....	<b>6</b>
Intended use .....	6
Safety regulations .....	7
Safety assessment .....	7
Use of qualified personnel .....	7
Warranty and liability .....	7
Disposal .....	7
For your safety .....	8
<b>Unit features</b> .....	<b>8</b>
<b>Function description</b> .....	<b>9</b>
Basic function .....	9
Block diagram .....	9
Operating distances .....	10
Lateral and vertical offset .....	12
<b>Wiring</b> .....	<b>18</b>
Important information .....	18
Pin assignment, connector and cable .....	18
<b>Connection to evaluation devices</b> .....	<b>19</b>
Single connection .....	19
Connection to Pilz evaluation devices .....	20
<b>Teaching in the actuator</b> .....	<b>21</b>
<b>Installation</b> .....	<b>21</b>
General .....	21
Safety switch .....	23
Actuator 6.1 .....	24
Actuator 6.1 low profile .....	24
Align safety switch and actuator .....	26
Use in operating heights higher than 2000 m above sea level .....	28
<b>Adjustment</b> .....	<b>28</b>
<b>Operation</b> .....	<b>28</b>
Normal mode .....	29
Error display .....	30

<b>Dimensions in mm</b> .....	<b>31</b>
<b>Technical details safety switch</b> .....	<b>32</b>
<b>Technical details actuator</b> .....	<b>36</b>
<b>Classification according to ZVEI, CB24I</b> .....	<b>38</b>
<b>Safety characteristic data</b> .....	<b>38</b>
<b>Supplementary data</b> .....	<b>39</b>
Radio approval.....	39
<b>Order reference</b> .....	<b>40</b>
Safety switch.....	40
Actuator .....	40
Complete systems .....	40
Accessories .....	40
<b>EC declaration of conformity</b> .....	<b>41</b>

## Introduction

### Validity of documentation

This documentation is valid for the product PSEN cs6.1n. It is valid until new documentation is published.

This operating manual explains the function and operation, describes the installation and provides guidelines on how to connect the product.

### Using the documentation

This document is intended for instruction. Only install and commission the product if you have read and understood this document. The document should be retained for future reference.

### Definition of symbols

Information that is particularly important is identified as follows:



#### **DANGER!**

This warning must be heeded! It warns of a hazardous situation that poses an immediate threat of serious injury and death and indicates preventive measures that can be taken.



#### **WARNING!**

This warning must be heeded! It warns of a hazardous situation that could lead to serious injury and death and indicates preventive measures that can be taken.



#### **CAUTION!**

This refers to a hazard that can lead to a less serious or minor injury plus material damage, and also provides information on preventive measures that can be taken.



#### **NOTICE**

This describes a situation in which the product or devices could be damaged and also provides information on preventive measures that can be taken. It also highlights areas within the text that are of particular importance.



### INFORMATION

This gives advice on applications and provides information on special features.

## Safety

### Intended use

The safety functions of the safety switch are:

- ▶ Safe shutdown of safety outputs when the actuator is removed beyond the assured release distance  $s_{ar}$  or when the actuator is not detected
- ▶ Remain shut down safely after the actuator has been removed

The safety switch meets the requirements in accordance with:

- ▶ EN 60947-5-3: PDDB with one of the approved actuators
- ▶ EN 62061: SIL CL 3
- ▶ EN ISO 13849-1: PL e (Cat. 4)
- ▶ EN ISO 14119: Coding level High, type 4

The safety switch may only be used with one of the approved actuators.

The safety level PL e (Cat. 4)/SIL CL 3 is only achieved if

- ▶ the safety outputs use 2-channel processing.

The following is deemed improper use in particular

- ▶ Any component, technical or electrical modification to the product,
- ▶ Use of the product outside the areas described in this manual,
- ▶ Use of the product outside the technical details (see [Technical details](#)  32]).



### NOTICE

#### EMC-compliant electrical installation

The product is designed for use in an industrial environment. The product may cause interference if installed in other environments. If installed in other environments, measures should be taken to comply with the applicable standards and directives for the respective installation site with regard to interference.

Approved actuators:

- ▶ PSEN cs6.1
- ▶ PSEN cs6.1 low profile glue
- ▶ PSEN cs6.1 low profile screw

## Safety regulations

### Safety assessment

Before using a device it is necessary to perform a safety assessment in accordance with the Machinery Directive.

Functional safety is guaranteed for the product as a single component. However, this does not guarantee the functional safety of the overall plant/machine. In order to achieve the required safety level for the overall plant/machine, define the safety requirements for the plant/machine and then define how these must be implemented from a technical and organisational standpoint.

### Use of qualified personnel

The products may only be assembled, installed, programmed, commissioned, operated, maintained and decommissioned by competent persons.

A competent person is a qualified and knowledgeable person who, because of their training, experience and current professional activity, has the specialist knowledge required. To be able to inspect, assess and operate devices, systems and machines, the person has to be informed of the state of the art and the applicable national, European and international laws, directives and standards.

It is the company's responsibility only to employ personnel who

- ▶ Are familiar with the basic regulations concerning health and safety / accident prevention,
- ▶ Have read and understood the information provided in the section entitled Safety
- ▶ Have a good knowledge of the generic and specialist standards applicable to the specific application.

### Warranty and liability

All claims to warranty and liability will be rendered invalid if

- ▶ The product was used contrary to the purpose for which it is intended,
- ▶ Damage can be attributed to not having followed the guidelines in the manual,
- ▶ Operating personnel are not suitably qualified,
- ▶ Any type of modification has been made (e.g. exchanging components on the PCB boards, soldering work etc.).

### Disposal

- ▶ In safety-related applications, please comply with the mission time  $T_M$  in the safety-related characteristic data.
- ▶ When decommissioning, please comply with local regulations regarding the disposal of electronic devices (e.g. Electrical and Electronic Equipment Act).

**For your safety****WARNING!****Loss of safety function due to manipulation of the interlocking device**

Manipulation of the interlocking device may lead to serious injury and death.

- You should prevent any possibility of the interlocking device being manipulated through the use of a spare actuator.
- Keep the substitute actuator in a safe place and protect it from unauthorised access.
- If spare actuators are used, these must be installed as described in [Installation](#) [ 21].
- If the original actuators are replaced with substitute actuators, the original actuators must be destroyed before disposal.

- ▶ Do not remove the connector's protective cap until you are just about to connect the unit. This will prevent potential contamination.

**Unit features**

- ▶ Transponder technology for presence detection
- ▶ Pilz coding type: fully coded
- ▶ Dual-channel operation
- ▶ 2 safety outputs
- ▶ 1 signal output
- ▶ LED display for:
  - State of the actuator
  - State of the inputs (always lights up yellow)
  - Supply voltage/fault
- ▶ 4 actuation directions, each with 3 approach directions (see [Explanation of markings](#) [ 10])
  - Square marking for normal operating distance
  - Triangle marking for short operating distance
  - 2 semicircle markings for a lateral approach. Please note the Lateral and vertical offset with the lateral approach to the semicircle marking.

The guaranteed safe operating distances for the specified selections only apply when the actuator approaches the switch vertically. With the other approach directions, the operating distances may sometimes be considerably larger (particularly when approaching the semicircle).

## Function description

### Basic function

The safety outputs may have a high or low signal, depending on the position of the actuator.

State of the outputs:

Actuator in the re- sponse range	Safety output 12	Safety output 22	Signal output Y32
Yes	High	High	High
No	Low	Low	Low

### Block diagram

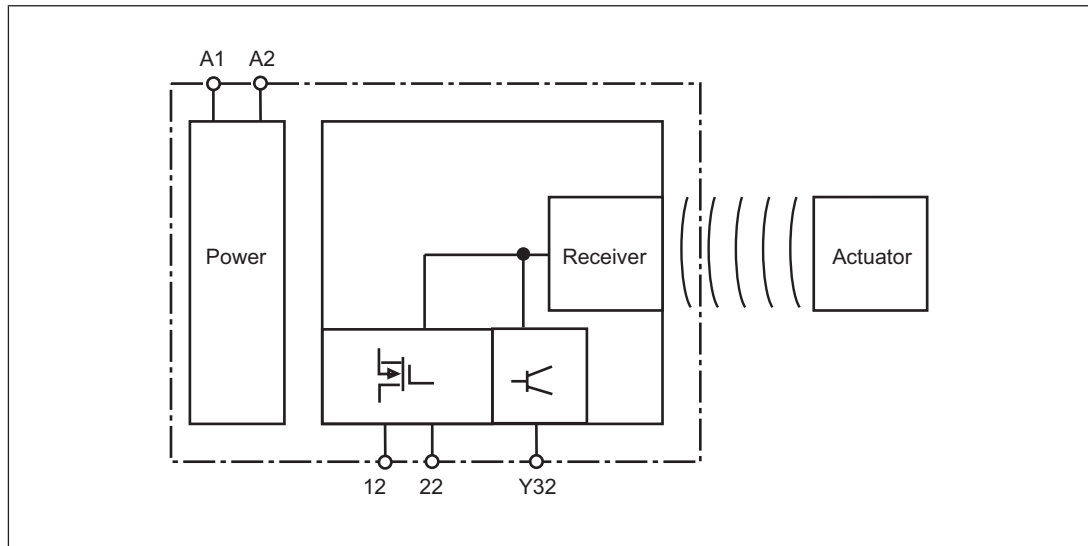

**Operating distances**

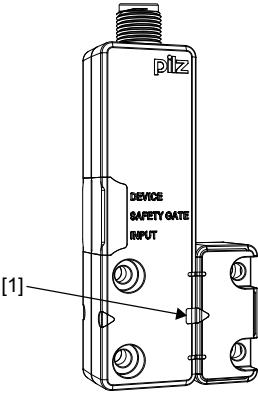
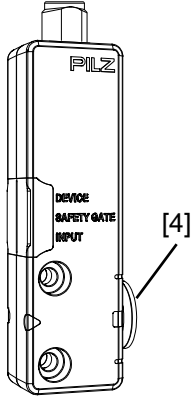
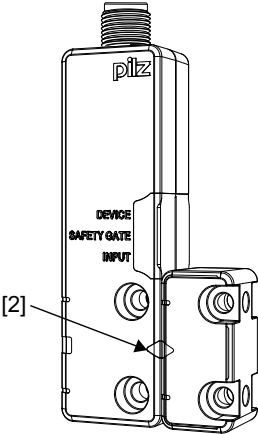
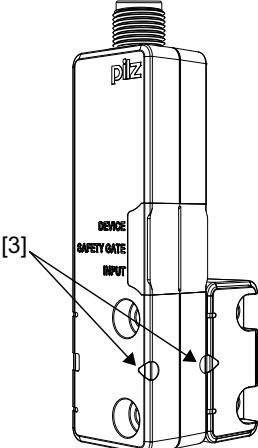
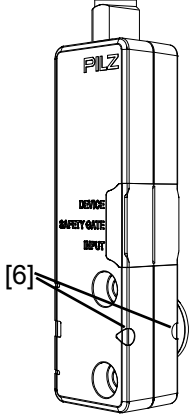
Actuator PSEN cs6.1	Actuator PSEN cs6.1 low profile glue or PSEN cs6.1 low pro- file screw	Operating distances
 <p>[1]</p>	 <p>[4]</p>	<p>[1] Actuator PSEN cs6.1 aligned to the square marking on the switch</p> <p><math>S_{ao}</math> Assured operating distance: 8 mm  <math>S_{ar}</math> Assured release distance: 20 mm  <math>S_o</math> Typical operating distance: 11 mm  <math>S_r</math> Typical release distance: 14 mm</p> <p>[4] Actuator PSEN cs6.1 low profile glue or PSEN cs6.1 low profile screw aligned to the square marking on the switch</p> <p><math>S_{ao}</math> Assured operating distance: 5 mm  <math>S_{ar}</math> Assured release distance: 20 mm  <math>S_o</math> Typical operating distance: 10 mm  <math>S_r</math> Typical release distance: 12 mm</p>
 <p>[2]</p>		<p>[2] Actuator PSEN cs6.1 aligned to the triangle marking on the switch</p> <p><math>S_{ao}</math> Assured operating distance: 4 mm  <math>S_{ar}</math> Assured release distance: 12 mm  <math>S_o</math> Typical operating distance: 5 mm  <math>S_r</math> Typical release distance: 8 mm</p> <p>The alignment of the actuators PSEN cs6.1 low profile glue or PSEN cs6.1 low profile screw to the triangle marking is not provided for</p>
 <p>[3]</p>	 <p>[6]</p>	<p>[3] Actuator PSEN cs6.1 aligned to the semicircle marking on the switch</p> <p><math>S_{ao}</math> Assured operating distance: 3 mm  <math>S_{ar}</math> Assured release distance: 16 mm  <math>S_o</math> Typical operating distance: 6 mm  <math>S_r</math> Typical release distance: 8 mm</p> <p>[6] Actuator PSEN cs6.1 low profile glue or PSEN cs6.1 low profile screw aligned to the semicircle marking on the switch</p> <p><math>S_{ao}</math> Assured operating distance: 2 mm  <math>S_{ar}</math> Assured release distance: 14 mm  <math>S_o</math> Typical operating distance: 5 mm  <math>S_r</math> Typical release distance: 7 mm</p>

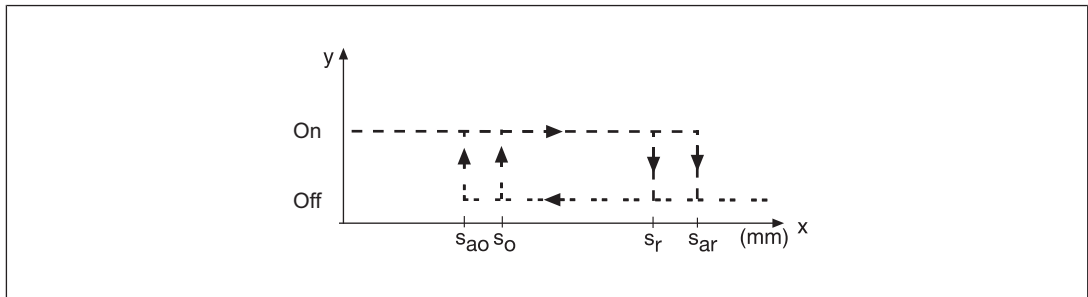

The switching distances of the actuators PSEN cs6.1 low profile glue and PSEN cs6.1 low profile screw were determined under the following conditions:

- ▶ Assured operating distance  $S_{ao}$  and assured release distance  $S_{ar}$ 
  - Measurement over the entire temperature range
  - Installed on various base materials
  - Taking into account product tolerances
- ▶ Typical operating distance  $S_o$  and typical release distance  $S_r$ 
  - Measured at room temperature
  - Installed on plastic

**Lateral and vertical offset**

**Lateral offset when aligning to the triangle or square marking**

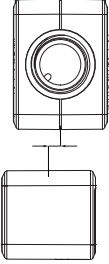
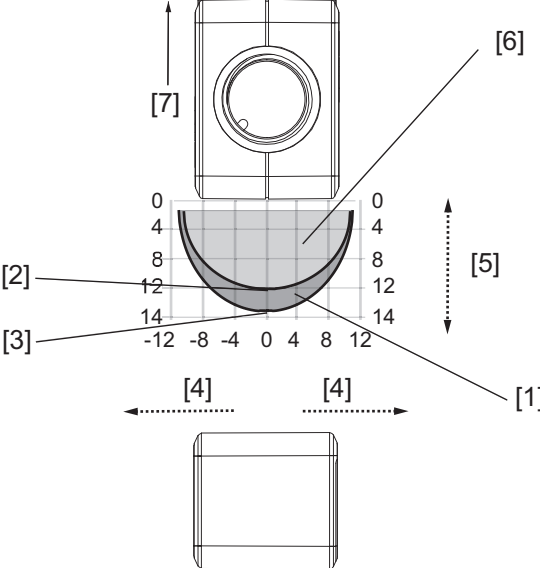
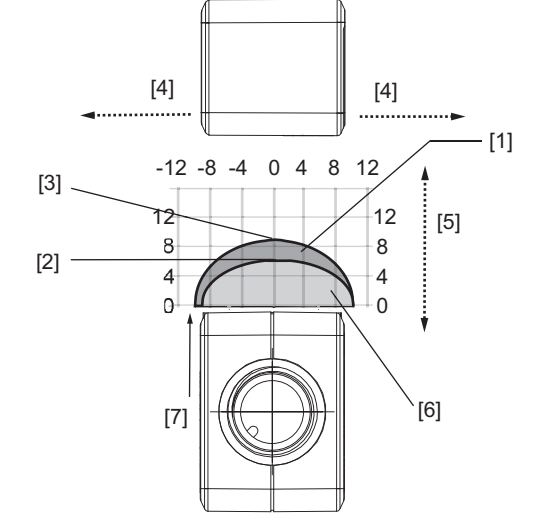
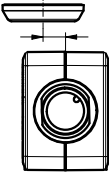
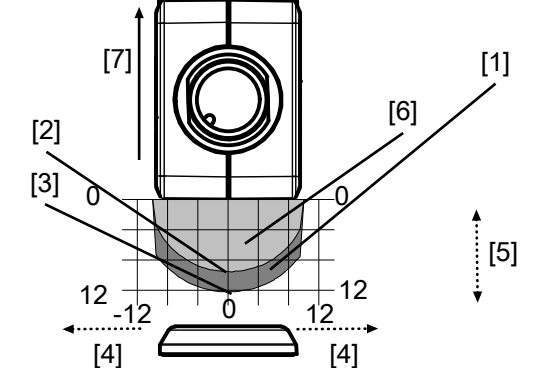
	Alignment 1: Actuator PSEN cs6.1 aligned to the square marking on the switch	Alignment 2: Actuator PSEN cs6.1 aligned to the triangle marking on the switch
		
	Alignment 1: Actuator PSEN cs6.1 low profile glue or PSEN cs6.1 low profile screw aligned to the square marking on the switch	Alignment 2: Actuator PSEN cs6.1 low profile glue or PSEN cs6.1 low profile screw aligned to the triangle marking on the switch
		<p>Actuator PSEN cs6.1 low profile glue or PSEN cs6.1 low profile screw to triangle marking is not suitable because the operating distances are too low.</p>

**Legend**

- [1] Hysteresis
- [2] Typical operating distance  $S_o$
- [3] Typical release distance  $S_r$
- [4] Offset in mm
- [5] Operating distance in mm
- [6] Response range
- [7] Status of LED

Lateral offset when aligning to the semicircle marking

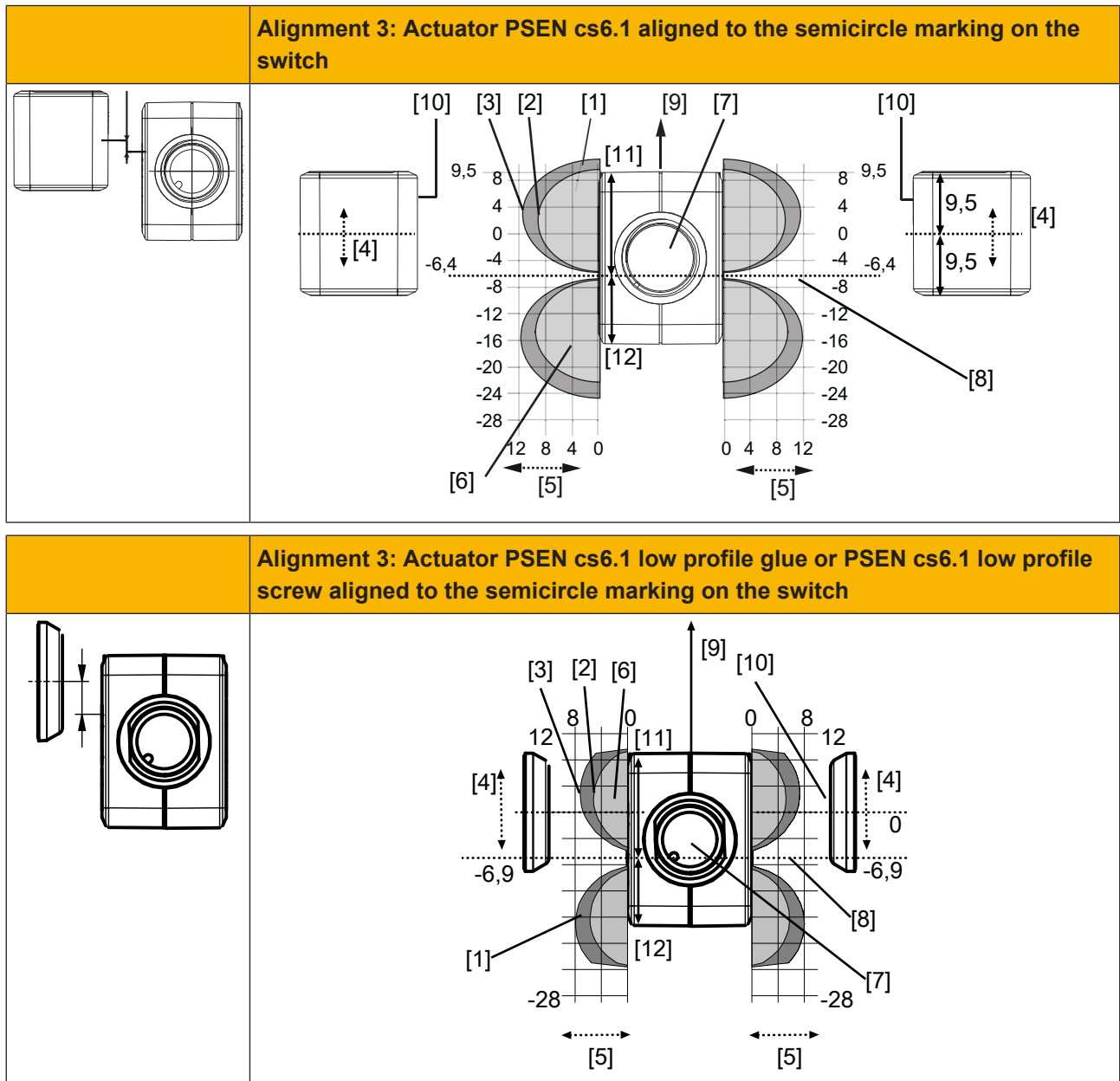

Legend

- [1] Hysteresis
- [2] Typical operating distance  $S_o$
- [3] Typical release distance  $S_r$
- [4] Offset in mm (distance of the middle of the actuator to the zero line in the grid)
- [5] Operating distance in mm
- [6] Response range
- [7] Connector on the safety switch
- [8] Limit of response range, position of gate hinge
- [9] Status of LED
- [10] Sensing face of the actuator, labelled with Pilz logo
- [11] Distance from the front edge of the safety switch to the limit of the response range (position of the gate end stop) = 15.9 mm
- [12] Distance from the front edge of the safety switch to the limit of the response range (position of the gate end stop) = 15.9 mm

[12] Distance from the rear edge of the safety switch to the limit of the response range (position of the gate end stop) = 10.5 mm

**Vertical offset when aligning to the triangle or square marking**

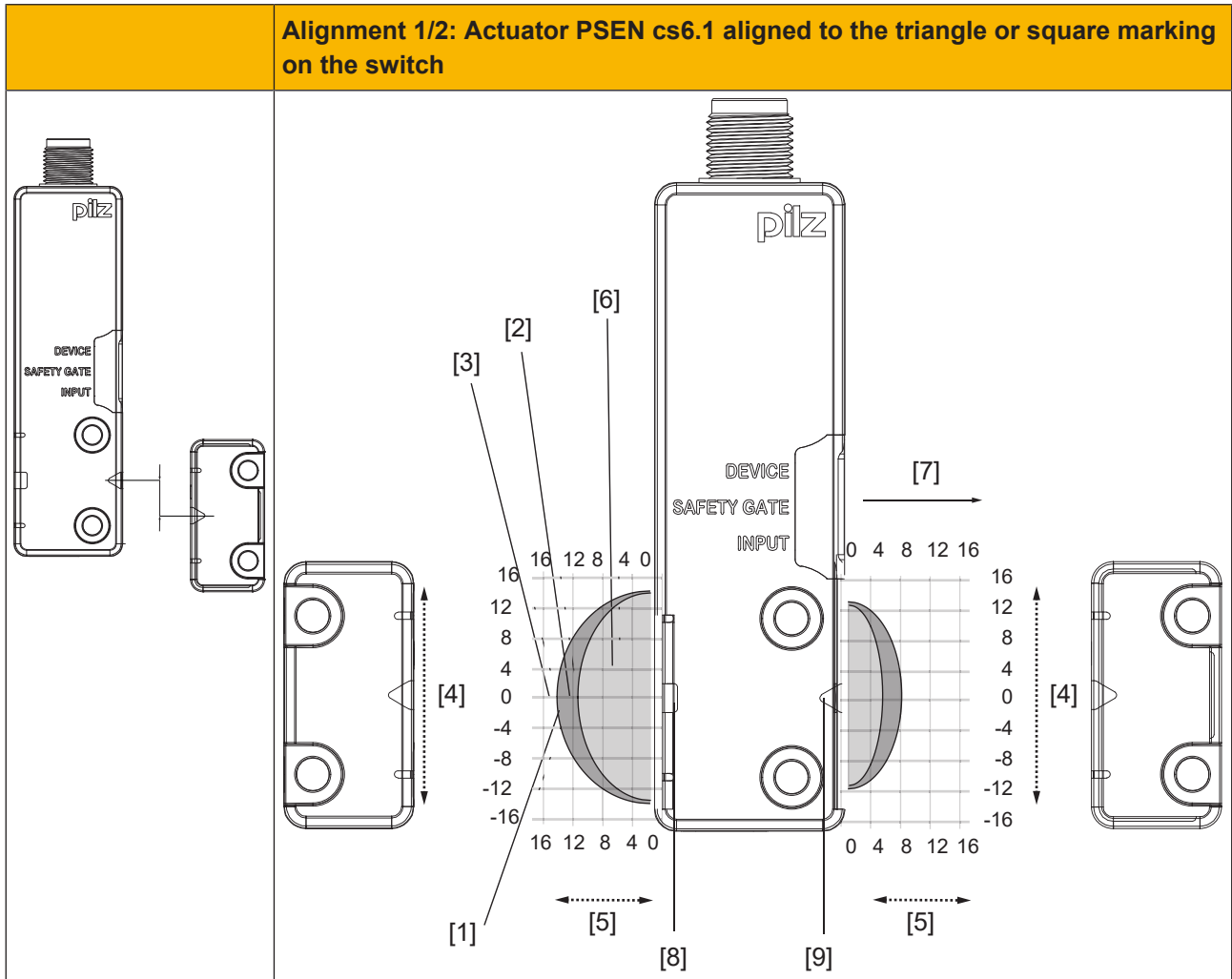

**Alignment 1/2: Actuator PSEN cs6.1 low profile glue or PSEN cs6.1 low profile screw aligned to the square marking on the switch**

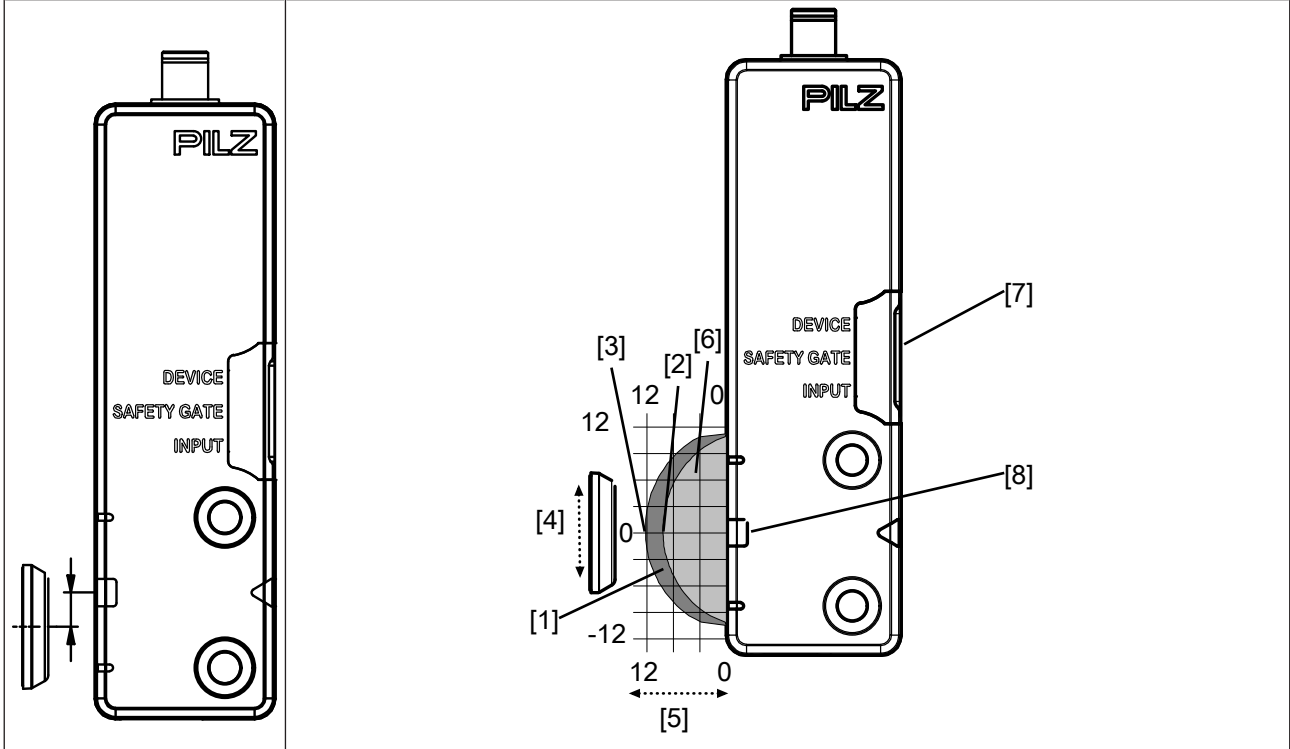

**Legend**

- [1] Hysteresis
- [2] Typical operating distance  $S_o$
- [3] Typical release distance  $S_r$
- [4] Offset in mm
- [5] Operating distance in mm
- [6] Response range
- [7] Status of LED
- [8] Square marking
- [9] Triangle marking

Vertical offset when aligning to the semicircle marking

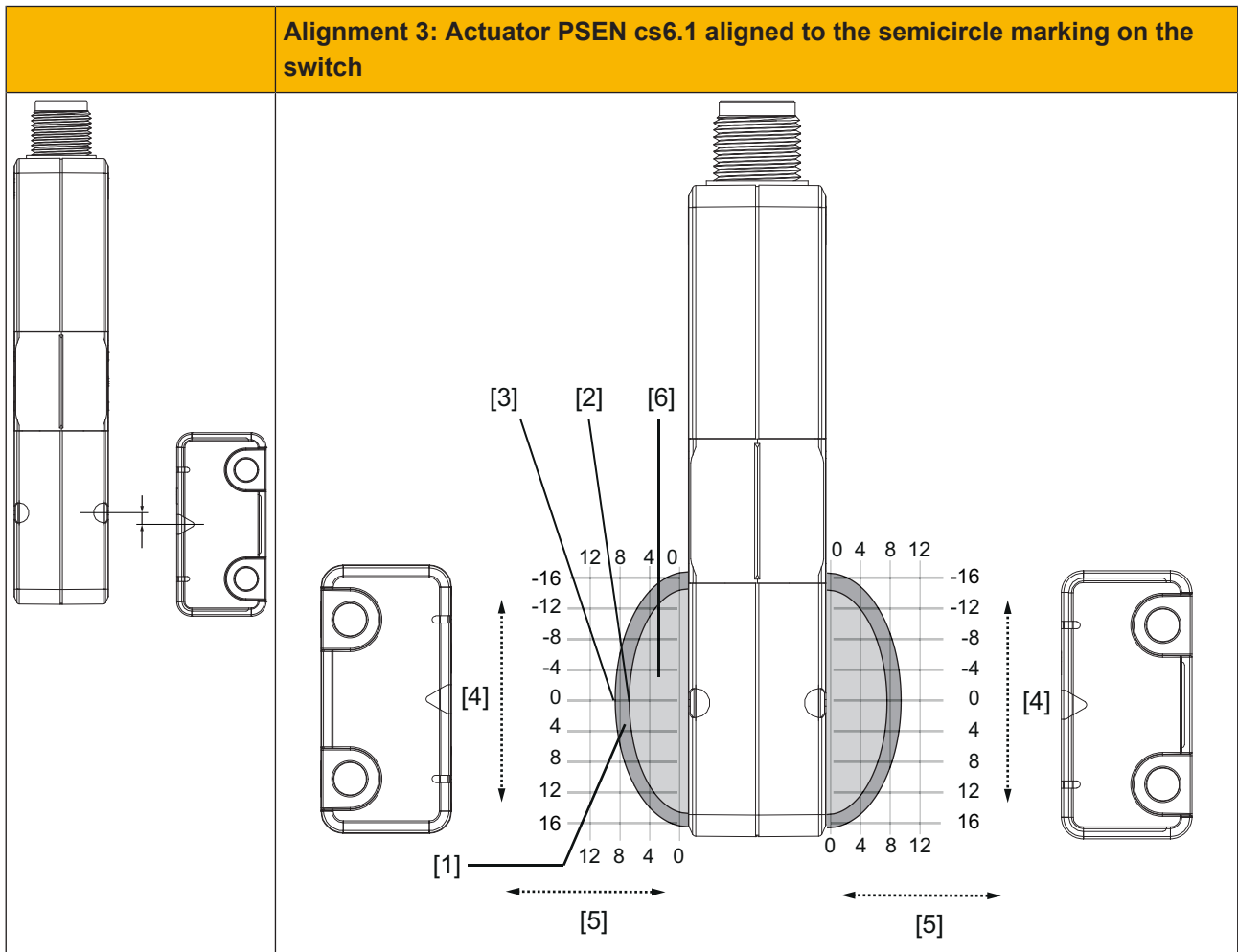

**Alignment 3: Actuator PSEN cs6.1 low profile glue or PSEN cs6.1 low profile screw aligned to the semicircle marking on the switch**

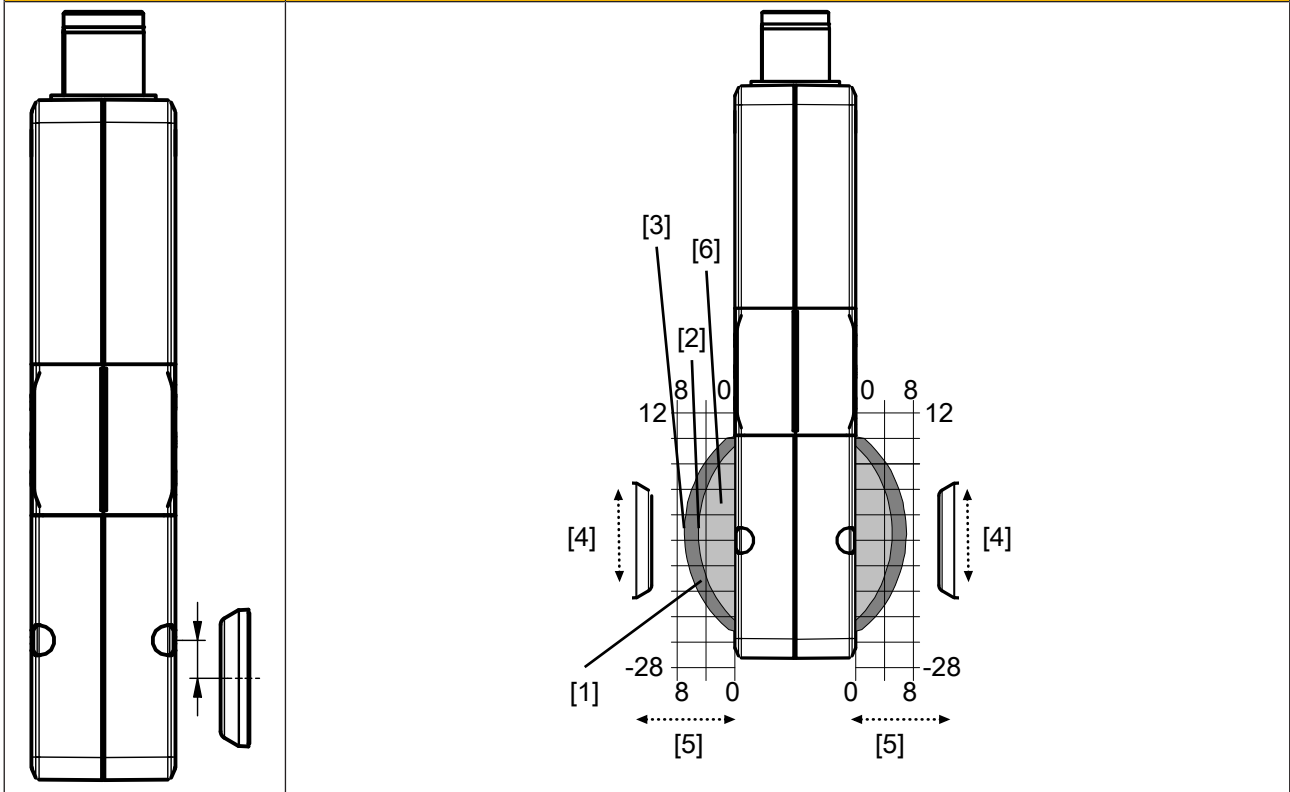

**Legend**

- [1] Hysteresis
- [2] Typical operating distance  $S_o$
- [3] Typical release distance  $S_r$
- [4] Offset in mm
- [5] Operating distance in mm
- [6] Response range

## Wiring

### Important information

- ▶ Information given in the [Technical details \[32\]](#) must be followed.
- ▶ Switch off the supply voltage before disconnecting the plug-in connection.
- ▶ Make sure that when connecting or separating the connector the pollution degree 1 or 2 is maintained.
- ▶ The power supply must meet the regulations for extra low voltages with protective electrical separation (SELV, PELV).
- ▶ The outputs of the safety switch must have a protective separation to voltages over 60 V AC.
- ▶ The supply voltage to the safety switch must be protected with a 2 A to 4 A quick-acting fuse.
- ▶ Ensure the wiring and EMC requirements of EN 60204-1 are met.

### Pin assignment, connector and cable

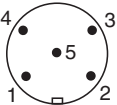
	5-pin M12 male connector
--	--------------------------

PIN	Pin designation	Function	Wire colour
1	A1	+24 V UB	brown
2	12	Output, channel1	white
3	A2	0 V UB	blue
4	22	Output, channel2	black
5	Y32	Signal output	grey

The wire colour also applies for the cable available from Pilz as an accessory.

### Connection to evaluation devices

Make sure that the selected evaluation device has the following properties:

- ▶ 2-channel with feasibility monitoring
- ▶ OSSD signals are evaluated

#### Single connection



**CAUTION!**

**Do not connect the signal output to 0 V!**

If the signal output Y32 is connected to 0 V, the safety switch may be damaged as a result. Connect the signal output Y32 to a consumer, e.g. to the input on a control system, or leave the signal output unconnected. Also note the max. current (see [Technical details \[32\]](#)).

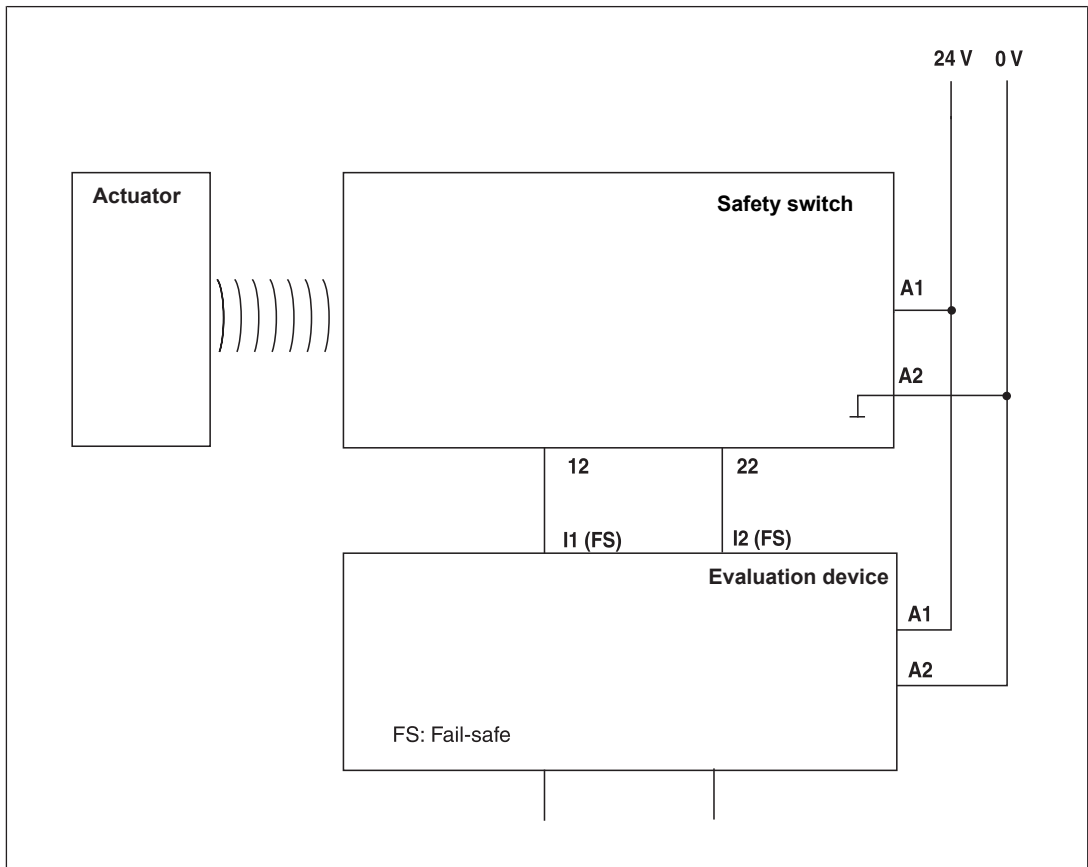

### Connection to Pilz evaluation devices

The safety switch PSEN cs6.1n can be connected to Pilz evaluation devices, for example.

Suitable Pilz evaluation devices are, for example:

- ▶ PNOZelog for safety gate monitoring
- ▶ PNOZpower for safety gate monitoring
- ▶ PNOZsigma for safety gate monitoring
- ▶ PNOZ X for safety gate monitoring
- ▶ PNOZmulti for safety gate monitoring  
Configure the safety switch in the PNOZmulti Configurator with switch type 3.
- ▶ PSS for safety gate monitoring with standard function block SB064, SB066 or FS\_Safety Gate

The correct connection to the respective evaluation device is described in the operating manual for the evaluation device. Make sure that the connection is made in accordance with the specifications in the operating manual for the selected evaluation device.

The connections to two evaluation devices are shown on the following pages, by way of example:

- ▶ PNOZ s3 and
- ▶ PNOZmulti

#### PNOZ s3

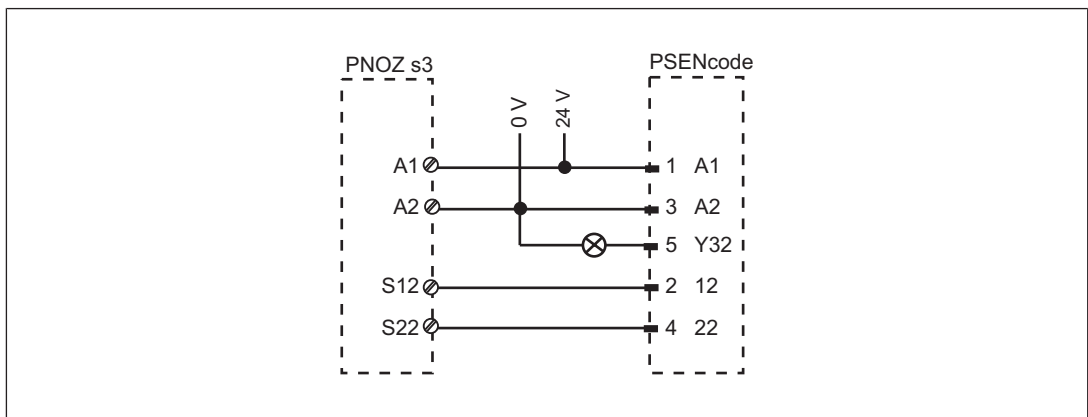

#### PNOZmulti

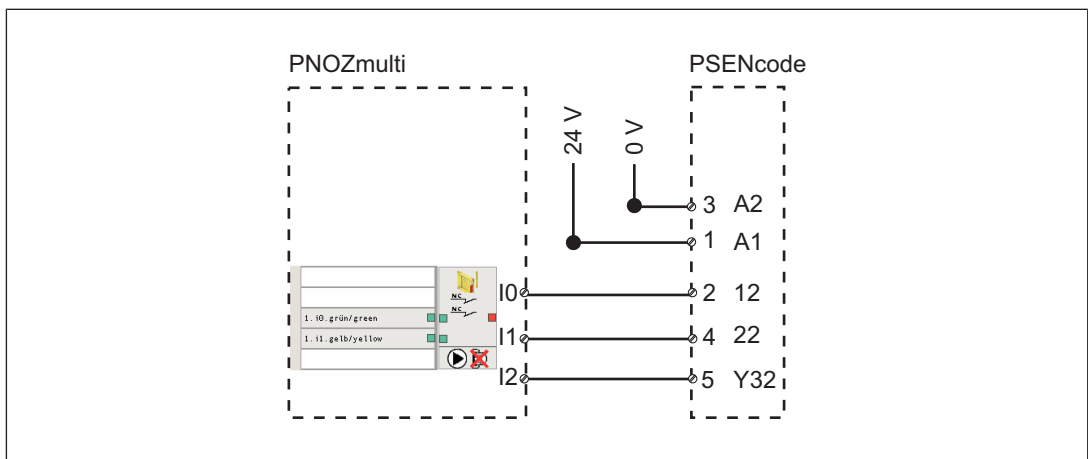

## Teaching in the actuator

### Teaching in the actuator for the first time:

The first actuator to be detected by the safety switch (see [Intended use](#) [📖 6]) is taught in automatically as soon as it is brought into the response range.

### To teach in a new actuator:

A maximum of 8 learning procedures are possible.

1. The actuator that is to be taught in must be brought into the safety switch's response range as the only transponder. As soon as the actuator is detected, the "Safety Gate" LED will flash yellow.
2. After 20 s has elapsed, the "Safety Gate" LED turns to quick yellow flashes. Trigger a system reset in the next 120 s by interrupting the power supply.
3. When the supply voltage is switched back on, the learning procedure is complete and the number of permitted additional learning procedures is reduced by 1.



#### NOTICE

- The actuator must not be removed during the learning procedure.
- It is no longer possible to re-teach this actuator on the same safety switch.

## Installation

### General



#### CAUTION!

##### Potential loss of safety function due to changed device properties

The unit's properties may be affected if installed in an environment containing electrically or magnetically conductive material.

- Please check the operating distances and the assured release distance.

- ▶ The safety switch and actuator should be installed opposite each other in parallel. Make sure that the actuator is aligned to the marking on the safety switch that guarantees the operating distance required by the plant design (see [Operating distances](#) [📖 10]).
- ▶ Torque setting: Please note the information provided under [Technical details](#) [📖 32].
- ▶ The distance between two safety switches must be maintained (see [Technical details](#) [📖 32]).  
The distance can be undershot in certain application cases (see diagrams).

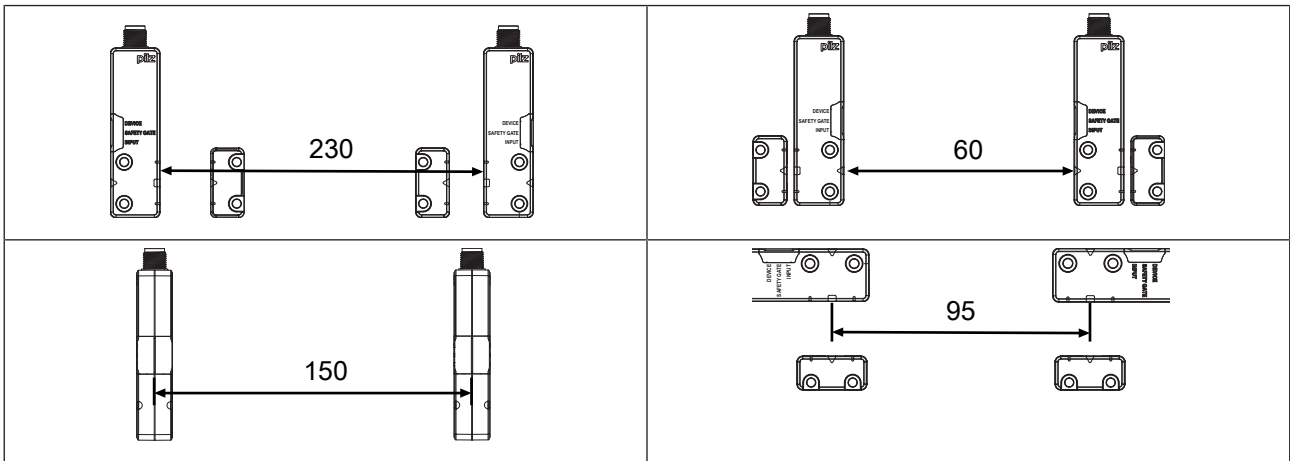

- ▶ Make sure that the safety switch and actuator cannot be used as an end stop.
- ▶ Please note the installation measures in accordance with EN ISO 14119 for a safety switch design 4 and with level of coding High.
- ▶ Please note the permitted bending radii for the cable (see [Technical details](#) [32]), to avoid excessive force on the individual strands.
- ▶ Make sure that the bend protection is not damaged. Such damage can cause the whole product to fail.
- ▶ For simpler installation, the mounting brackets (see [Order reference for Accessories](#) [40]) can be used.



**WARNING!**

**Loss of safety function due to non-permitted enlargement of the assured release distance when using both switching lobes (aligned at semicircle marking)**

Depending on the application, serious injury or death may result.

- Install a mechanical stop when using the response range at the semicircle marking, to avoid unintended switching off at the limit of the response range and to prevent the maximum release distance from enlarging impermissibly by using both switching lobes.

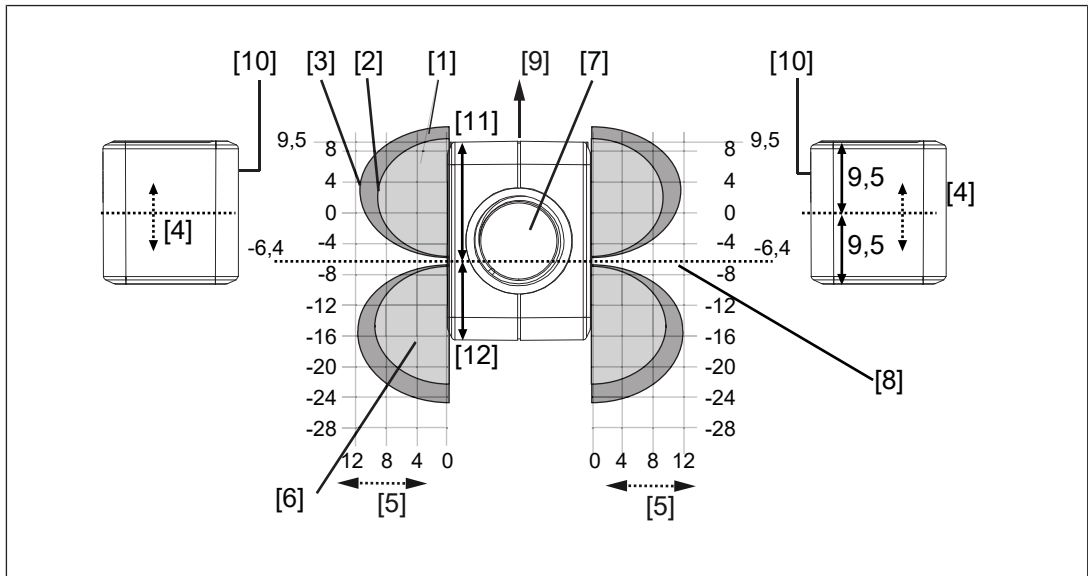

**Legend**

- [1] Hysteresis
- [2] Typical operating distance  $S_o$
- [3] Typical release distance  $S_r$
- [4] Offset in mm (distance of the middle of the actuator to the zero line in the grid)
- [5] Operating distance in mm
- [6] Response range
- [7] Connector on the safety switch
- [8] Limit of response range, position of gate hinge
- [9] Status of LED
- [10] Sensing face of the actuator, labelled with Pilz logo
- [11] Distance from the front edge of the safety switch to the limit of the response range (position of the gate end stop) = 15.9 mm
- [12] Distance from the rear edge of the safety switch to the limit of the response range (position of the gate end stop) = 10.5 mm

**Safety switch**

- ▶ Safety switches should only be secured using M4 screws with a flat head (e.g. M4 cheese-head or pan head screws).

**Procedure:**

1. Provide the mounting surface with two drill holes for fastening the safety switch (see [Dimensions in mm](#) [31]).
2. Use a screw to fix the safety switch to the mounting surface.  
Make sure that the safety switch marking that is to be used for operation can be operated using the actuator from the right side.
3. Do not fully tighten the second screw on the safety switch.

## Actuator 6.1

### Procedure actuator PSEN cs6.1

1. Provide the mounting surface with two drill holes for fastening the actuator (see [Dimensions](#) [ 31]).
2. Use a screw to fix the actuator to the mounting surface.  
Make sure that the actuator with the marking (triangle) points towards the marking on the safety switch.
3. Do not fully tighten the second screw on the actuator.

### Actuator 6.1 low profile



#### **WARNING!**

#### **Loss of the manipulation protection by inadequate environmental conditions**

The loss of the manipulation protection can allow manipulation of the interlocking device and it may lead to serious injury or death.

- Make sure that the actuator has no direct or repetitive contact with materials such as methyl ethyl ketone (MEK), petrol or isopropanol.

- ▶ The actuator is secured against unauthorised removal, and against contamination by the sealing. The seal should be regarded as equivalent to using permanent fastenings in accordance with EN ISO 14119.
- ▶ By removing the actuator, the actuator will be destroyed.
- ▶ The actuator's adhesive force on the materials aluminium, stainless steel, polycarbonate and glass was checked. For deviating surface materials check the adhesive force on the surface.
- ▶ After a cure time of 24 hours, 90 % of the final adhesive force are achieved. The hardening must take place at min. 20 °C. With lower temperatures the cure time is clearly extended.
- ▶ No continuous force must affect the actuator.

### Procedure actuator PSEN cs6.1 low profile glue:

1. To seal the low profile actuators correctly, it is necessary to prepare the surface to which the actuator is to be attached.

The surface must be clean, dry and free of grease.

Wipe off any solved grease and contaminations with a new, dry paper cloth.

Clean the surface with 70% isopropanol. Use lint-free paper cloths and change the paper cloths frequently.

The adhesive surface is clean when the paper remains clean.

The cleaned surfaces must be sealed immediately to prevent any new contamination by dust and fingerprints.

2. Remove the protective foil from the assembly aid and fix it flush with the sides (see diagram) to the required sensing area of the safety switch.
3. Place the actuator into the assembly aid so that the actuator's covered adhesive surface is on the surface.

Make sure that the actuator's centre is on the same level as the orientation arrows of the sensor and in the centre of the sensor.

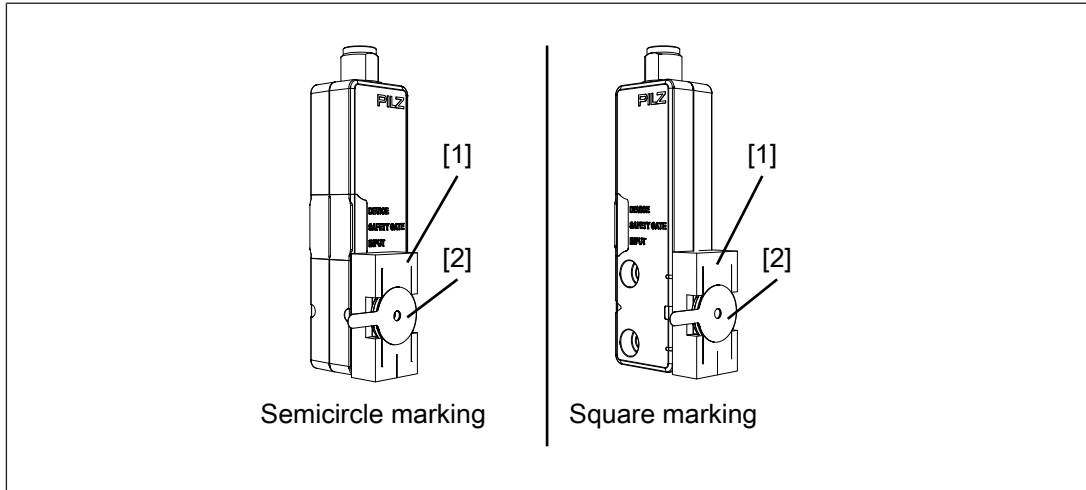



Fig.: Safety switch with assembly aid and low profile actuator oriented to semicircle and square marking

### Legend

- [1] Assembly aid for low profile actuator
- [2] low profile actuator

4. Remove the protective foil from the adhesive foil of the actuator.  
Do not touch the adhesive foil after removing the protective foil!
5. Close the safety gate carefully and then press the actuator to the adhesive position.
6. Press on the actuator for at least 3 seconds with approx. 50 N.  
After this time, an adhesive force of approx. 50 % is achieved. The full adhesive force is achieved after 72 hours at an ambient temperature of at least 20 °C.
7. Check the adhesive force of the glue after 10 minutes.  
The actuator must no move when pressed sideways.
8. Remove the assembly aid from the safety switch and clean the sensing area of the safety switch.

### Procedure actuator PSEN cs6.1 low profile screw

1. Provide the mounting surface with a drill hole for an additional screw connection of the actuator (see [Dimensions in mm](#)  31]).
2. To seal the low profile actuators correctly, it is necessary to prepare the surface to which the actuator is to be attached.  
The surface must be clean, dry and free of grease.  
Wipe off any solved grease and contaminations with a new, dry paper cloth.

Clean the surface with 70% isopropanol. Use lint-free paper cloths and change the paper cloths frequently.

The adhesive surface is clean when the paper remains clean.

The cleaned surfaces must be sealed immediately to prevent any new contamination by dust and fingerprints.

3. Remove the protective foil from the adhesive foil of the actuator.

Do not touch the adhesive foil after removing the protective foil!

4. Insert the screw into the actuator's hole and position the screw at the hole on the mounting surface.

To screw on the actuator, use the supplied plastic M3 countersunk screw.

When using a screw made from metal the operating distance change, please note the **Warning**  21].

5. Then press the actuator firmly to the gluing position.

6. Press on the actuator for at least 3 seconds with approx. 50 N.

After this time, an adhesive force of approx. 50 % is achieved. The full adhesive force is achieved after 72 hours at an ambient temperature of at least 20 °C.

7. Check the adhesive force of the glue after 10 minutes.

The actuator must not move when pressed sideways.

8. Additionally, attach the actuator using the M3 plastic screw supplied.

#### **Align safety switch and actuator**

- ▶ The actuator should only be secured using M4 screws with a flat head (e.g. M4 cheese-head or pan head screws).

The actuator should be protected from unauthorised removal and from contamination.

Close the mounting holes using the seals provided. The use of seals should be regarded as equivalent to using permanent fastenings in accordance with EN ISO 14119.

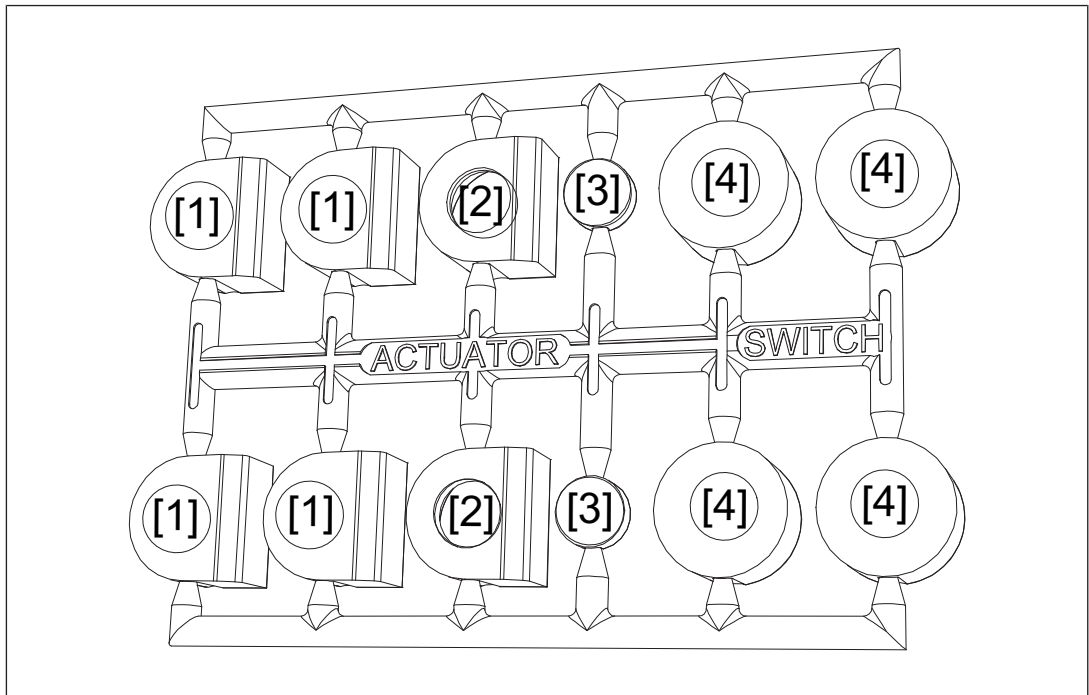

**Legend**

- [1] 4 seals for actuators
- [2] Unused seals
- [3] 2 seals for actuators
- [4] 2 seals for switches, 2 seals unused

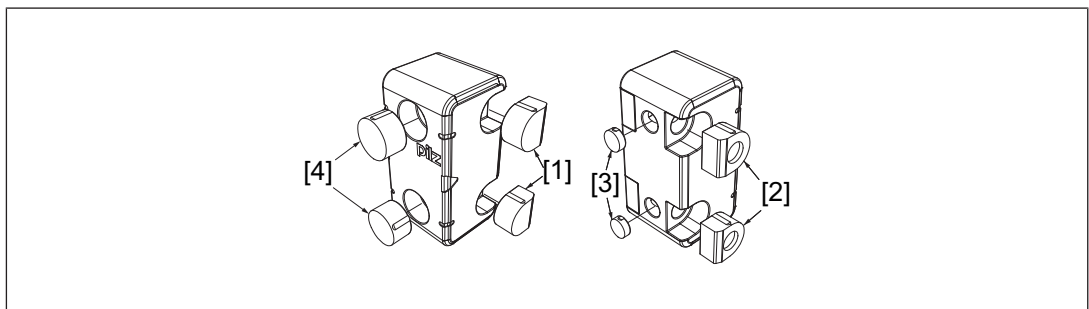

Fig.: Applying the screw covers [1] and [3] on the actuator

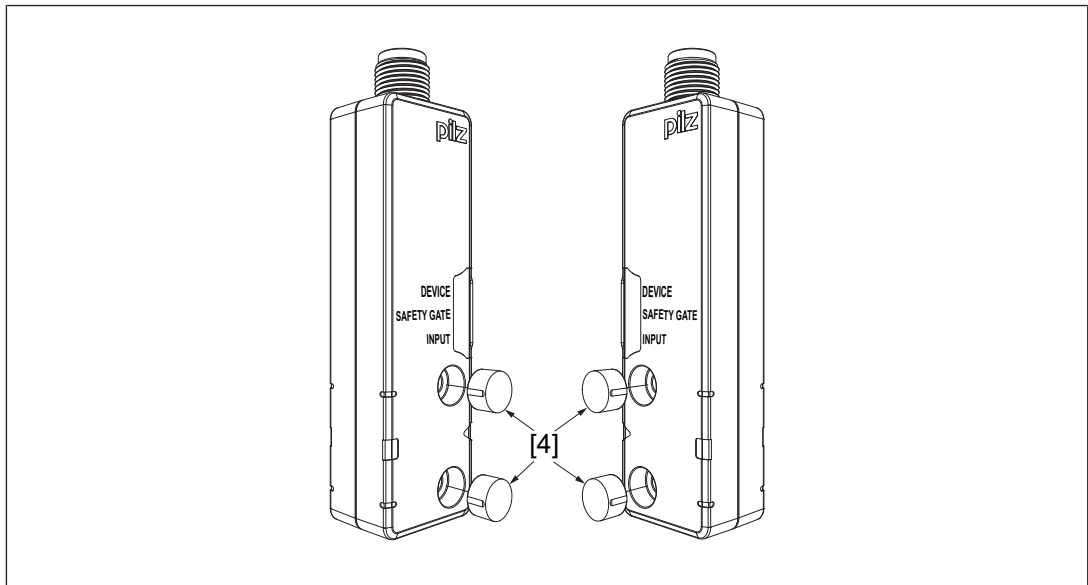

Fig.: Applying the screw cover [4] on the switch

#### Procedure:

1. Align the safety switch and tighten the screws.
2. Actuator PSEN cs6.1  
Align the actuator and tighten the screws.
3. Use the seals to close the mounting holes on the sensing face of the safety switch (see diagram, [4]).

#### Use in operating heights higher than 2000 m above sea level

When using the PSEN cs6.1n note the reduced max. ambient temperature of +60 °C at a height of 2000 m to 4000 m.

#### Adjustment

- ▶ The stated operating distances (see [Technical details \[32\]](#)) only apply when the safety switch and actuator are installed facing each other in parallel. Operating distances may deviate if other arrangements are used.
- ▶ Note the maximum permitted lateral and vertical offset (see [Operating distances \[10\]](#) and [Lateral and vertical offset \[12\]](#)).

#### Operation







#### NOTICE





The safety function should be checked after initial commissioning and each time the plant/machine is changed. The safety functions may only be checked by qualified personnel.

**Status indicators:**





**Legend:**

	LED off
	LED on
	LED flashes (500 ms on, 500 ms off)
	LED flashes quickly (50 ms on, 950 ms off)
	LED flashes very quickly (30 ms on, 470 ms off)













**Normal mode**

LED status		Switch status
Device	 green	Ready for operation
Safety gate	 yel- low	Actuator is within the response range
	 Off	Actuator is outside the response range
Input	 yel- low	The unit is ready for operation

**LED display actuator teach-in**

LED status			Switch status	Remedy / measure
Device	Safety Gate	Input		
 Green	 yellow	Display not definitive	Teaching actuator. Duration approx. 20 seconds	-
 Green	 yellow	Display not definitive	Actuator teach-in complete.	Switch voltage off and then on again.

**Error display**

LED status			Switch status	Remedy / measure
Device	Safety Gate	Input		
 Red	 off	 off	Internal error on switch	Change the switch.
 Red	 Yellow	 Yellow	Supply voltage is outside the tolerance range	Ensure the voltage supply corresponds to the <a href="#">Technical details [32]</a> .
 Yellow	Display not definitive	Display not definitive	Supply voltage is at the limit of the tolerance range	Ensure the voltage supply corresponds to the <a href="#">Technical details [32]</a> .
 Red	Display of last status	Display of last status	Outputs in fault condition	Check the outputs and switch the voltage off and then on again.
 Green	 Yellow	Display not definitive	Wrong actuator	Use the actuator that has been taught-in or teach in a new actuator (see <a href="#">Teaching in the actuator [21]</a> ).
 off	 Yellow	 Yellow	Switch doesn't start	Change the switch.

### Dimensions in mm

Safety switch	
<p>Front view of the safety switch. Dimensions: total height 90 mm, mounting hole offset 11.6 mm, width 26.4 mm, LED offset 7.4 mm, and terminal spacing 22 mm and 7.5 mm. Markings [1], [2], and [3] are indicated.</p>	<p>Side view of the safety switch. Dimensions: total height 101.6 mm and width 19 mm. Markings [4] are indicated.</p>
Actuator	
<p>Front view of the actuator. Dimensions: width 18 mm, mounting hole offset 7.5 mm, hole diameter <math>\text{Ø } 4.5</math> mm, and terminal spacing 22 mm and 8.3 mm. Marking [2] is indicated.</p>	<p>Side view of the actuator. Dimensions: total height 37 mm, mounting hole offset 8.3 mm, hole diameter <math>\text{Ø } 4.5</math> mm, terminal spacing 22 mm and 7.5 mm, and width 19 mm. Marking [2] is indicated.</p>

**Legend:**

- [1] Square marking
- [2] Triangle marking
- [3] LEDs
- [4] Semicircle marking

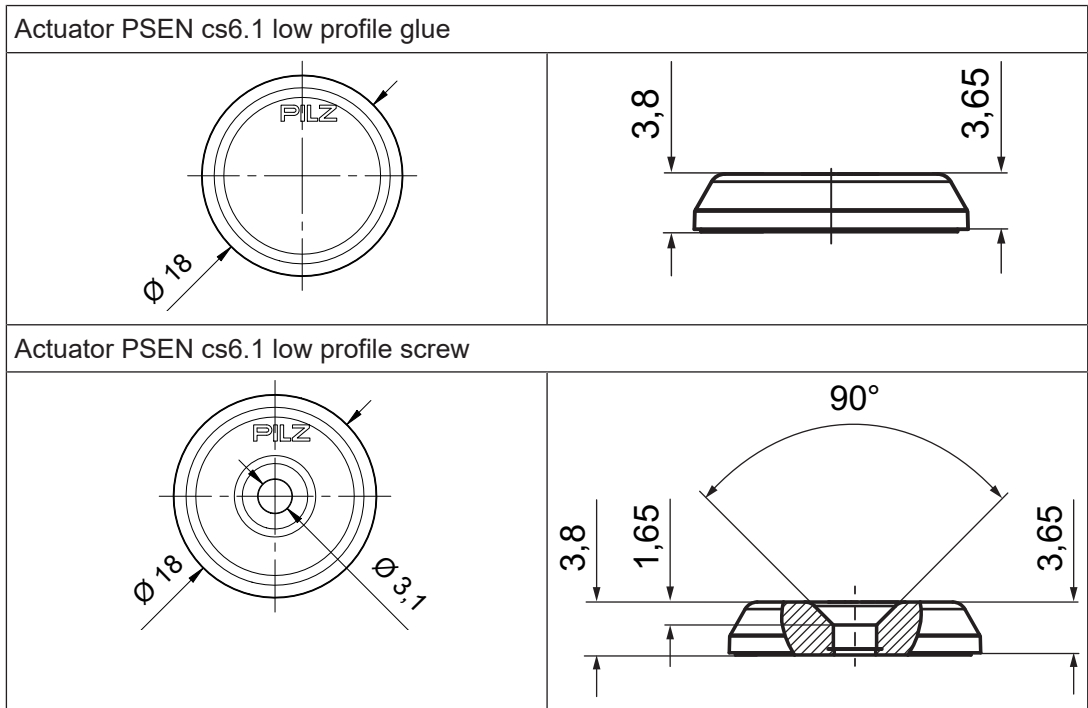

### Technical details safety switch

#### General

Certifications	CE, EAC (Eurasian), ECOLAB, FCC, IC, TÜV, cULus Listed
Sensor's mode of operation	Transponder
Coding level in accordance with EN ISO 14119	High
Design in accordance with EN ISO 14119	4
Classification in accordance with EN 60947-5-3	PDDb
Pilz coding type	fully coded

#### Transponder

Frequency band	122 kHz - 128 kHz
Max. transmitter output	15 mW

#### Electrical data

Supply voltage	
Voltage	24 V
Kind	DC
Voltage tolerance	-20 %/+20 %
Output of external power supply (DC)	1 W
Max. switching frequency	3 Hz
Max. cable capacitance at the safety outputs	
No-load, PNOZ with relay contacts	40 nF
PNOZmulti, PNOZelog, PSS	40 nF
Max. inrush current impulse	
Current pulse, A1	0,5 A
No-load current	25 mA

<b>Semiconductor outputs</b>	
OSSD safety outputs	<b>2</b>
Signal outputs	<b>1</b>
Switching current per output	<b>100 mA</b>
Breaking capacity per output	<b>2,4 W</b>
Potential isolation from system voltage	<b>No</b>
Short circuit-proof	<b>yes</b>
Residual current at outputs	<b>400 µA</b>
Voltage drop at OSSDs	<b>1 V</b>
Conditional rated short circuit current	<b>100 A</b>
Lowest operating current	<b>2 mA</b>
Utilisation category in accordance with EN 60947-1	<b>DC-12</b>
<b>Times</b>	
Test pulse duration, safety outputs	<b>150 µs</b>
Switch-on delay	
after UB is applied	<b>1 s</b>
Actuator typ.	<b>30 ms</b>
Actuator max.	<b>50 ms</b>
Delay-on de-energisation	
Actuator typ.	<b>30 ms</b>
Actuator max.	<b>40 ms</b>
Risk time in accordance with EN 60947-5-3	<b>150 ms</b>
Supply interruption before de-energisation	<b>20 ms</b>
Simultaneity, channel 1 and 2 max.	<b>∞</b>
<b>Environmental data</b>	
Ambient temperature	
In accordance with the standard	<b>EN 60068-2-14</b>
Temperature range	<b>-25 - 70 °C</b>
Max. at max. operating height	<b>+60 °C</b>
Max. at max. operating height <2000 m	<b>+70 °C</b>
Storage temperature	
In accordance with the standard	<b>EN 60068-2-1/-2</b>
Temperature range	<b>-40 - 85 °C</b>
Climatic suitability	
In accordance with the standard	<b>EN 60068-2-30</b>
Humidity	<b>93 % r. h. at 40 °C</b>
Max. operating height above sea level	<b>4000 m</b>
EMC	<b>EN 60947-5-3</b>
Vibration	
In accordance with the standard	<b>EN 60947-5-2</b>
Frequency	<b>10 - 55 Hz</b>
Amplitude	<b>1 mm</b>

**Environmental data**

## Shock stress

In accordance with the standard	<b>EN 60947-5-2</b>
Acceleration	<b>30g</b>
Duration	<b>11 ms</b>

## Airgap creepage

Overvoltage category	<b>III</b>
Pollution degree	<b>3</b>

## Rated insulation voltage

**75 V**

## Rated impulse withstand voltage

**1 kV**

## Protection type

Housing	<b>IP66, IP67</b>
---------	-------------------

**Operating distances**

## Actuator 1

Type	<b>PSEN cs6.1</b>
Repetition accuracy switching distances	<b>3 %</b>
Change of operating distance with temperature changes	<b>+0,02mm/°C</b>

## Actuator 2

Type	<b>PSEN cs6.1 low profile glue</b>
Repetition accuracy switching distances	<b>3 %</b>
Change of operating distance with temperature changes	<b>+0,02mm/°C</b>

## Actuator 3

Type	<b>PSEN cs6.1 low profile screw</b>
Repetition accuracy switching distances	<b>3 %</b>
Change of operating distance with temperature changes	<b>+0,02mm/°C</b>

**Operating distances when the actuator approaches square marking**

## Actuator 1

Type	<b>PSEN cs6.1</b>
Assured operating distance Sao	<b>8 mm</b>
Assured release distance Sar	<b>20 mm</b>
Typical operating distance So	<b>11 mm</b>
Typical release distance Sr	<b>14 mm</b>
Typical hysteresis	<b>2 mm</b>

## Actuator 2

Type	<b>PSEN cs6.1 low profile glue</b>
Assured operating distance Sao	<b>5 mm</b>
Assured release distance Sar	<b>20 mm</b>
Typical operating distance So	<b>10 mm</b>
Typical release distance Sr	<b>12 mm</b>
Typical hysteresis	<b>2 mm</b>

### Operating distances when the actuator approaches square marking

#### Actuator 3

Type	<b>PSEN cs6.1 low profile screw</b>
Assured operating distance $S_{ao}$	<b>5 mm</b>
Assured release distance $S_{ar}$	<b>20 mm</b>
Typical operating distance $S_o$	<b>10 mm</b>
Typical release distance $S_r$	<b>12 mm</b>
Typical hysteresis	<b>2 mm</b>

### Operating distances when the actuator approaches triangle marking

#### Actuator 1

Type	<b>PSEN cs6.1</b>
Assured operating distance $S_{ao}$	<b>4 mm</b>
Assured release distance $S_{ar}$	<b>12 mm</b>
Typical operating distance $S_o$	<b>5 mm</b>
Typical release distance $S_r$	<b>8 mm</b>
Typical hysteresis	<b>2 mm</b>

### Operating distances when the actuator approaches semicircle marking

#### Actuator 1

Type	<b>PSEN cs6.1</b>
Assured operating distance $S_{ao}$	<b>3 mm</b>
Assured release distance $S_{ar}$	<b>16 mm</b>
Typical operating distance $S_o$	<b>6 mm</b>
Typical release distance $S_r$	<b>8 mm</b>
Typical hysteresis	<b>2 mm</b>

#### Actuator 2

Type	<b>PSEN cs6.1 low profile glue</b>
Assured operating distance $S_{ao}$	<b>2 mm</b>
Assured release distance $S_{ar}$	<b>14 mm</b>
Typical operating distance $S_o$	<b>5 mm</b>
Typical release distance $S_r$	<b>7 mm</b>
Typical hysteresis	<b>2 mm</b>

#### Actuator 3

Type	<b>PSEN cs6.1 low profile screw</b>
Assured operating distance $S_{ao}$	<b>2 mm</b>
Assured release distance $S_{ar}$	<b>14 mm</b>
Typical operating distance $S_o$	<b>5 mm</b>
Typical release distance $S_r$	<b>7 mm</b>
Typical hysteresis	<b>2 mm</b>

### Mechanical data

Min. distance between safety switches	<b>250 mm</b>
Sensor flush installation in accordance with EN 60947-5-2	<b>Yes, follow installation guidelines</b>
Connection type	<b>M12, 5-pin male connector</b>

**Mechanical data**

Material	<b>PA+GF, PBT, polycarbonate</b>
Max. torque setting for fixing screws	<b>1 Nm</b>
Dimensions	
Height	<b>26,4 mm</b>
Width	<b>101,6 mm</b>
Depth	<b>19 mm</b>
Weight	<b>68 g</b>

Where standards are undated, the 2015-11 latest editions shall apply.

**Technical details actuator**

**Order no. 542183 PSEN cs6.1**

See below for more order numbers

**General**

Certifications	<b>CE, EAC (Eurasian), ECOLAB, TÜV, cULus Listed</b>
Sensor's mode of operation	<b>Transponder</b>
Coding level in accordance with EN ISO 14119	<b>High</b>
Pilz coding type	<b>fully coded</b>

**Transponder**

Frequency band	<b>122 kHz - 128 kHz</b>
----------------	--------------------------

**Environmental data**

## Ambient temperature

In accordance with the standard	<b>EN 60068-2-14</b>
Temperature range	<b>-25 - 70 °C</b>
Max. at max. operating height	<b>+60 °C</b>
Max. at max. operating height <2000 m	<b>+70 °C</b>

## Storage temperature

In accordance with the standard	<b>EN 60068-2-1/-2</b>
Temperature range	<b>-40 - 85 °C</b>

## Climatic suitability

In accordance with the standard	<b>EN 60068-2-30</b>
Humidity	<b>93 % r. h. at 40 °C</b>

Max. operating height above sea level	<b>4000 m</b>
---------------------------------------	---------------

EMC	<b>EN 60947-5-3</b>
-----	---------------------

## Vibration

In accordance with the standard	<b>EN 60947-5-2</b>
Frequency	<b>10 - 55 Hz</b>
Amplitude	<b>1 mm</b>

## Shock stress

In accordance with the standard	<b>EN 60947-5-2</b>
Acceleration	<b>30g</b>
Duration	<b>11 ms</b>

## Protection type

Housing	<b>IP66, IP67</b>
---------	-------------------

<b>Mechanical data</b>	
Material	<b>PBT</b>
Max. torque setting for fixing screws	<b>1 Nm</b>
Dimensions	
Height	<b>18 mm</b>
Width	<b>37 mm</b>
Depth	<b>19 mm</b>
Weight	<b>15 g</b>

**Order no. 542187 PSEN cs6.1 low profile glue**

**Order no. 542188 PSEN cs6.1 low profile screw**

<b>General</b>	<b>542187</b>	<b>542188</b>
Certifications	<b>CE, EAC (Eurasian), TÜV, cULus Listed</b>	<b>CE, EAC (Eurasian), TÜV, cULus Listed</b>
Sensor's mode of operation	<b>Transponder</b>	<b>Transponder</b>
Coding level in accordance with EN ISO 14119	<b>High</b>	<b>High</b>
Pilz coding type	<b>fully coded</b>	<b>fully coded</b>
<b>Transponder</b>	<b>542187</b>	<b>542188</b>
Frequency band	<b>122 kHz - 128 kHz</b>	<b>122 kHz - 128 kHz</b>
<b>Environmental data</b>	<b>542187</b>	<b>542188</b>
Ambient temperature		
In accordance with the standard	<b>EN 60068-2-14</b>	<b>EN 60068-2-14</b>
Temperature range	<b>-25 - 70 °C</b>	<b>-25 - 70 °C</b>
Max. at max. operating height	<b>+60 °C</b>	<b>+60 °C</b>
Max. at max. operating height <2000 m	<b>+70 °C</b>	<b>+70 °C</b>
Storage temperature		
In accordance with the standard	<b>EN 60068-2-1/-2</b>	<b>EN 60068-2-1/-2</b>
Temperature range	<b>-40 - 85 °C</b>	<b>-40 - 85 °C</b>
Climatic suitability		
In accordance with the standard	<b>EN 60068-2-30</b>	<b>EN 60068-2-30</b>
Humidity	<b>93 % r. h. at 40 °C</b>	<b>93 % r. h. at 40 °C</b>
Max. operating height above sea level	<b>4000 m</b>	<b>4000 m</b>
EMC	<b>EN 60947-5-3</b>	<b>EN 60947-5-3</b>
Vibration		
In accordance with the standard	<b>EN 60947-5-2</b>	<b>EN 60947-5-2</b>
Frequency	<b>10 - 55 Hz</b>	<b>10 - 55 Hz</b>
Amplitude	<b>1 mm</b>	<b>1 mm</b>
Shock stress		
In accordance with the standard	<b>EN 60947-5-2</b>	<b>EN 60947-5-2</b>
Acceleration	<b>30g</b>	<b>30g</b>
Duration	<b>11 ms</b>	<b>11 ms</b>
Protection type		
Housing	<b>IP67</b>	<b>IP67</b>

Mechanical data	542187	542188
Material		
Top	<b>PBT</b>	<b>PBT</b>
Max. torque setting for fixing screws	–	<b>0,1 Nm</b>
Dimensions		
Height	<b>3,8 mm</b>	<b>3,8 mm</b>
Width	<b>18 mm</b>	<b>18 mm</b>
Depth	<b>18 mm</b>	<b>18 mm</b>
Weight	<b>2 g</b>	<b>2 g</b>

Where standards are undated, the 2015-11 latest editions shall apply.

### Classification according to ZVEI, CB24I

The following tables describe the classes and specific values of the product interface and the classes of interfaces compatible with it. The classification is described in the ZVEI position paper "Classification of Binary 24 V Interfaces - Functional Safety aspects covered by dynamic testing".

Single-pole output	
Interfaces	
Source	
Interface	Sensor
Class	C2
Drain	
Class	C1, C2
Source parameters	
Max. test pulse duration	150 µs
Max. rated current	0,1 A
Max. capacitive load	40 nF

### Safety characteristic data



#### NOTICE

You must comply with the safety characteristic data in order to achieve the required safety level for your plant/machine.

Operating mode	EN ISO 13849-1: 2015	EN ISO 13849-1: 2015	EN 62061 SIL CL	EN 62061 PFH <sub>D</sub> [1/h]	IEC 61511 SIL	IEC 61511 PFD	EN ISO 13849-1: 2015 T <sub>M</sub> [year]
	PL	Category					
2-ch. OSSD	<b>PL e</b>	<b>Cat. 4</b>	<b>SIL CL 3</b>	<b>9,56E-10</b>	–	<b>8,51E-06</b>	<b>20</b>

Explanatory notes for the safety-related characteristic data:

- ▶ The SIL CL value in accordance with EN 62061 corresponds to the SIL value in accordance with EN 61508.
- ▶  $T_M$  is the maximum mission time in accordance with EN ISO 13849-1. The value also applies as the retest interval in accordance with EN 61508-6 and IEC 61511 and as the proof test interval and mission time in accordance with EN 62061.

All the units used within a safety function must be considered when calculating the safety characteristic data.



#### INFORMATION

A safety function's SIL/PL values are **not** identical to the SIL/PL values of the units that are used and may be different. We recommend that you use the PAScal software tool to calculate the safety function's SIL/PL values.

## Supplementary data

### Radio approval

USA/Canada

**FCC** ID: VT8-PSENC55  
**IC:** 7482A-PSENC55

FCC/IC-Requirements:

This product complies with Part 15 of the FCC Rules and with Industry Canada licence-exempt RSS standards.

Operation is subject to the following two conditions:

- 1) this product may not cause harmful interference, and
- 2) this product must accept any interference received, including interference that may cause undesired operation.

Changes or modifications made to this product not expressly approved by Pilz may void the FCC authorization to operate this equipment.

NOTE: This equipment has been tested and found to comply with the limits for a Class A digital device, pursuant to Part 15 of the FCC Rules. These limits are designed to provide reasonable protection against harmful interference when the equipment is operated in a commercial environment. This equipment generates, uses, and can radiate radio frequency energy and, if not installed and used in accordance with the instruction manual, may cause harmful interference to radio communications. Operation of this equipment in a residential area is likely to cause harmful interference in which case the user will be required to correct the interference at his own expense.

Le présent produit est conforme aux CNR d'Industrie Canada applicables aux appareils radio exempts de licence. L'exploitation est autorisée aux deux conditions suivantes:

- (1) le produit ne doit pas produire de brouillage, et
- (2) l'utilisateur de le produit doit accepter tout brouillage radioélectrique subi, même si le brouillage est susceptible d'en compromettre le fonctionnement.

## Order reference

### Safety switch

Product type	Features		Order no.
PSEN cs6.1n 1switch	Safety switch, fully coded	5-pin M12 connector	542 153

### Actuator

Product type	Features		Order no.
PSEN cs6.1 M12 1actuator	Actuator, fully coded		542 183
PSEN cs6.1 low pro- file glue 1 actuator	Actuator fully coded, without screw		542 187
PSEN cs6.1 low pro- file screw 1 actuator	Actuator fully coded, with screw		542 188

### Complete systems

Product type	Features		Order no.
PSEN cs6.1n/PSEN cs6.1 M12 1unit	Safety gate system, fully coded	5-pin M12 connector	542 103

### Accessories

#### Installation materials

Product type	Features		Order no.
PSEN bracket	Mounting bracket		532 110
PSEN mag/cs bracket straight	Mounting aid		532 111
PSEN screw M4x20 10pcs	Safety screws made from stainless steel with one-way slot		540 313
PSEN screw M4x26 10pcs	Safety screws made from stainless steel with one-way slot		540 314
PSEN cs1/2 bracket cable fix	Mechanical protection against defeat, protecting against unauthorised cable disconnection or damage for safety switches PSENcode cs1/2, PSENcode cs5/6 M12, PSENslock		532 112

### Cable

Product type	Connection 1	Connection 2	Length	Order No.
PSS67/PDP67 cable M12-5sf	Straight, M12, 5-pin, socket	Straight, M12, 5-pin, connector	3 m	380 208
			5 m	380 209
			10 m	380 210
			20 m	380 220
			30 m	380 211
PSS67/PDP67 cable M12-5af	Angled, M12, 5-pin, socket	Angled, M12, 5-pin, connector	3 m	380 212
			5 m	380 213
			10 m	380 214
			30 m	380 215
PSEN cable M12-5sf	Straight, M12, 5-pin, socket	Open cable	3 m	630 310
			5 m	630 311
			10 m	630 312
			20 m	630 298
			30 m	630 297
PSEN cable M12-5af	Angled, M12, 5-pin, socket	Open cable	3 m	630 347
			5 m	630 348
			10 m	630 349
			30 m	630 350

### Connection

Product type	Features	Order no.
PDP67 F 8DI ION	Decentralised input module IP67 for PNOZmulti with M12 thread	773 600
PDP67 F 8DI ION HP	Decentralised input module IP67 for PNOZmulti with M12 thread and additional supply voltage	773 601
PDP67 F 8DI ION VA	Decentralised input module IP67 for PNOZmulti with M12 thread in stainless steel	773 614
PDP67 F 8DI ION HP VA	Decentralised input module IP67 for PNOZmulti with M12 thread in stainless steel and additional supply voltage	773 615

### EC declaration of conformity

This product/these products meet the requirements of the following directives of the European Parliament and of the Council.

- ▶ 2006/42/EC on machines
- ▶ 2014/53/EC on radio equipment

The complete EC Declaration of Conformity is available on the Internet at [www.pilz.com/downloads](http://www.pilz.com/downloads).

Representative: Norbert Fröhlich, Pilz GmbH & Co. KG, Felix-Wankel-Str. 2, 73760 Ostfildern, Germany